

FEATURES

- Field-Bus remote data acquisition
- RS-485 Modbus RTU (Slave) communication
- 1 Universal Analogue Input
- 1 V/mA Analogue Input
- 2 4-20mA Analogue Outputs
- 3 Digital Inputs
- 1 SSR Digital Output + 2 Relay Outputs
- Watch-Dog Alarm
- 1500 Vac galvanic isolation on all ways
- High Accuracy
- EMC compliance – CE Mark
- DIN rail suitable mounting (EN-50022)

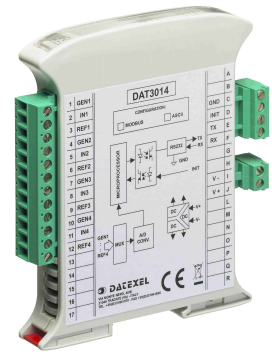
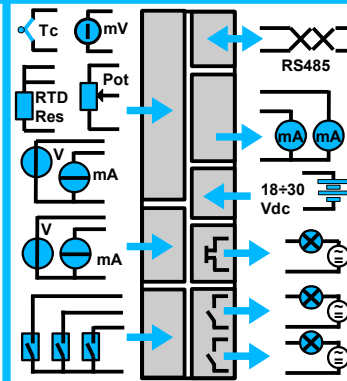

GENERAL DESCRIPTION

The DAT 3011 device is able to acquire RTD or Tc sensors, mV, V or mA input signals connected to the universal analogue input. Moreover a second V/mA analogue input is available. The device is able to acquire up to 3 digital inputs and to drive one solid-state relay and two SPST relays. Data values are transmitted with MODBUS RTU protocol on the RS-485 network.

By means of a 16 bit converter, the device guarantee a high accuracy and a stable measure versus time and temperature.

To ensure the plant safety, two Watch-Dog timer alarms are provided.

The 1500 Vac isolation on all ways removes eventual ground-loop effects, allowing the use of the device even in the heavy environmental conditions.

DAT 3011 is in compliance with the Directive 2004/108/EC on the electromagnetic compatibility.

The device is housed in a rough self-extinguishing plastic container which, thanks to its thin profile of 22.5mm only, allows a high density mounting on EN-50022 standard DIN rail.

USER INSTRUCTIONS

Before to install the device, please read the "Installation Instruction" section.

If the module configuration is unknown, it can be hardly to establish a communication with them; connecting the INIT terminal to the GND terminal (ground), at the next power-up the device will be auto-configured in the default settings (see Operating User Guide).

Connect power supply, serial bus and analogue inputs as shown in the "Wiring" section.

The "PWR" LED state depending to the working condition of the device: see the "Light Signalling" section to verify the device working state.

To perform configuration and calibration operations, read the instructions in the Operating User Guide.

To simplify handling or replacing of the device, it is possible to remove the wired terminals even with the device powered.

TECHNICAL SPECIFICATIONS

(Typical @ 25 °C and in the nominal conditions)

Analogue Inputs

Type	Range	Accuracy	Linearity	Thermal Drift
100 mV	-100 ÷ +100 mV	±0,05 % f.s.	±0,1 % f.s.	100 ppm/°C
1 V	-100 mV ÷ +1 V	±0,05 % f.s.	±0,1 % f.s.	100 ppm/°C
10 V	-10 ÷ +10 V	±0,05 % f.s.	±0,1 % f.s.	100 ppm/°C
20 mA	-20 ÷ 20 mA	±0,05 % f.s.	±0,1 % f.s.	100 ppm/°C
Pt100	-200 ÷ +850 °C	±0,05 % f.s.	±0,1 % f.s.	100 ppm/°C
Pt1K	-200 ÷ +200 °C	±0,05 % f.s.	±0,1 % f.s.	100 ppm/°C
Ni100	-60 ÷ +180°C	±0,05 % f.s.	±0,1 % f.s.	100 ppm/°C
Ni1K	-60 ÷ +150 °C	±0,05 % f.s.	±0,1 % f.s.	100 ppm/°C
Res	0 ÷ 2 Kohm	±0,05 % f.s.	±0,1 % f.s.	100 ppm/°C
Pot	0 ÷ 100 %	±0,05 % f.s.	±0,1 % f.s.	100 ppm/°C
Tc J	-210 ÷ +1200 °C	±0,05 % f.s.	±0,1 % f.s.	100 ppm/°C
Tc K	-210 ÷ +1370 °C	±0,05 % f.s.	±0,1 % f.s.	100 ppm/°C
Tc R	-50 ÷ +1760 °C	±0,05 % f.s.	±0,1 % f.s.	100 ppm/°C
Tc S	-50 ÷ +1760 °C	±0,05 % f.s.	±0,1 % f.s.	100 ppm/°C
Tc B	+400 ÷ +1825 C	±0,05 % f.s.	±0,1 % f.s.	100 ppm/°C
Tc E	-210 ÷ +1000 °C	±0,05 % f.s.	±0,1 % f.s.	100 ppm/°C
Tc T	-210 ÷ +400 °C	±0,05 % f.s.	±0,1 % f.s.	100 ppm/°C
Tc N	-210 ÷ +1300 °C	±0,05 % f.s.	±0,1 % f.s.	100 ppm/°C

Lead wire res. influence	RTD (3 wires) mV, Tc	0,05 %/Ω (50 Ω max) < 0.8 uV/Ohm
Excitation current	RTD, Res, Pot	~ 0.7 mA
Pot. Nominal value		2 Kohm
Sample Time		1 sec.
Warm-up time		3 min.

Analogue Output

Type	Range	Accuracy	Linearity	Thermal Drift
20 mA	0 / +20 mA	±0,1 % f.s.	±0,05 % f.s.	100 ppm/°C

Load Resistance	< 500 Ohm
Auxiliary Voltage	>12V

Digital Inputs

Channels	3
Input voltage (bipolar)	OFF State : 0÷3 V ON State : 10÷30 V
Input Impedance	4.7 KOhm

Digital Outputs

N.1 Solid State Relay (dry contacts)	Load Voltage 48 V (ac/dc), Load 0.4A max(resistive)
N.2 SPST Relays	
Max Load (resistive)	2 A @ 250 Vac (per contact) 2 A @ 30 Vdc (per contact)
Min Load	5Vdc , 10mA
Max Voltage	250Vac (50 / 60 Hz) , 110Vdc
Dielectric strength between contacts	1000 Vac, 50 Hz, 1 min.
Dielectric strength between coil and contacts	4000 Vac, 50 Hz, 1 min.

Serial Port

Type	RS-485
Protocol	Modbus RTU (Slave)
Baud Rate	up to 115200 bps

Power Supply

Supply Voltage	18 + 30 Vdc
Current Consumption	30 mA nom. (100mA max)
Reverse Polarity protection	60 Vdc max

Isolations

Isolation voltage	1500 Vac (on all ways)
-------------------	------------------------

EMC (for industrial environments)

Immunity	EN 61000-6-2
Emission	EN 61000-6-4

Temperature & Humidity

Operative temperature	-10°C .. +60°C
Storage temperature	-40°C .. +85°C
Relative humidity (not cond.)	0 .. 90 %

Housing

Material	Self-extinguishing plastic
Mounting	DIN rail EN-50022
Weight	about 150 g.

WIRING

ANALOG INPUT 0 - UNIVERSAL

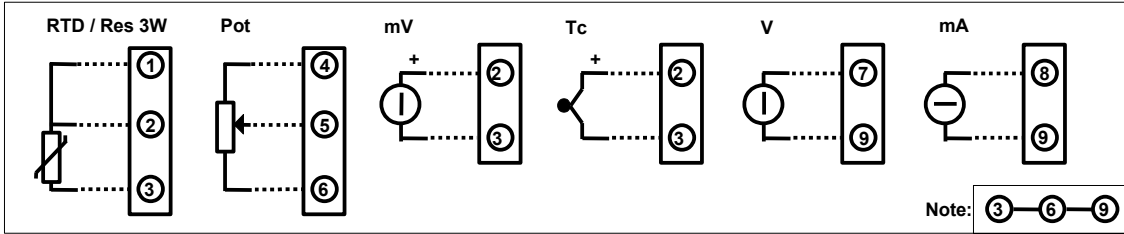

DIGITAL OUTPUTS

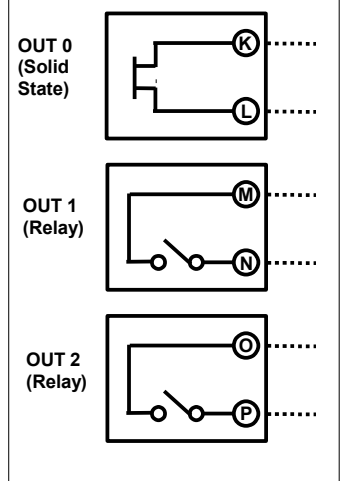

ANALOG INPUT 1 - V / mA

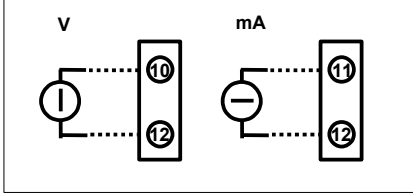

RS-485

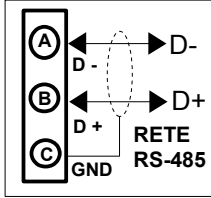

SUPPLY

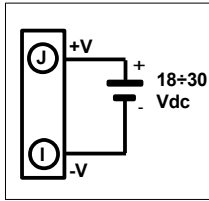

INIT

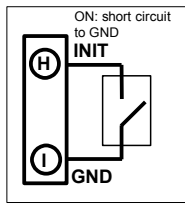

ANALOG OUTPUTS - mA

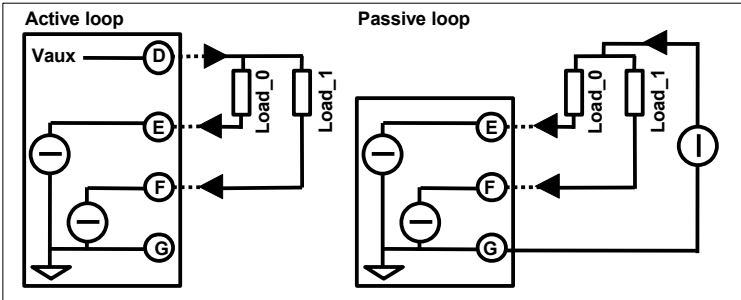

DIGITAL INPUTS

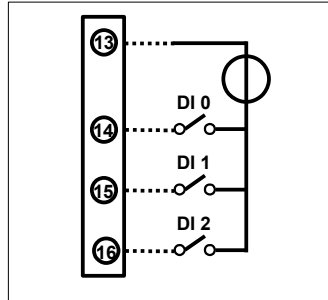

ISOLATIONS

1 UNIVERSAL ANALOG INPUT	RS485 LINE
1 V / mA INPUT	2 ANALOG OUTPUTS
3 DIGITAL INPUTS	SUPPLY
	1 SOLID STATE RELAY
	2 SPST RELAYS

INSTALLATION INSTRUCTIONS

The device is suitable for fitting to DIN rails in the vertical position. For optimum operation and long life follow these instructions:

When the devices are installed side by side it may be necessary to separate them by at least 5 mm in the following case:

- If panel temperature exceeds 45°C and at least one of the overload conditions exist.

Make sure that sufficient air flow is provided for the device avoiding to place raceways or other objects which could obstruct the ventilation slits. Moreover it is suggested to avoid that devices are mounted above appliances generating heat; their ideal place should be in the lower part of the panel. Install the device in a place without vibrations.

Moreover it is suggested to avoid routing conductors near power signal cables (motors, induction ovens, inverters etc...) and to use shielded cable for connecting signals.

LIGHT SIGNALLING

LED	COLOR	STATE	DESCRIPTION
PWR	GREEN	ON	Device powered
		OFF	Device not powered
STS	YELLOW	ON	System Error
		OFF	Correct working
RX	RED	BLINK	Data receiving from RS-485
		OFF	No Data receiving
TX	RED	BLINK	Data Transmission on RS-485
		OFF	No Data Transmission
I(n)	RED	ON	Digital Input 'n': ON State
		OFF	Digital Input 'n': OFF State
Q(n)	RED	ON	Digital Output 'n': ON State
		OFF	Digital Input 'n': OFF State

MODBUS REGISTERS MAPPING

Register	Description	Access
40001	--Reserved--	R/W
40002	Firmware [0]	R
40003	Firmware [1]	R
40004	Name [0]	R/W
40005	Name [1]	R/W
40006	--Reserved--	R/W
40007	Node ID	R/W
40008	--Reserved--	R/W
40009	Digital Inputs	R/W
40010	Digital Outputs	R/W
40011	System Flags	R/W
40012	--Reserved--	-

40018		
40019	COM Settings	R/W
40020	--Reserved--	-

40026		
40027	Analogue In 0	R
40028	Analogue In 1	R
40029	--Reserved--	-

40032		
40033	Analogue Out 0	R/W
40034	Analogue Out 1	R/W

MECHANICAL DIMENSIONS (mm)

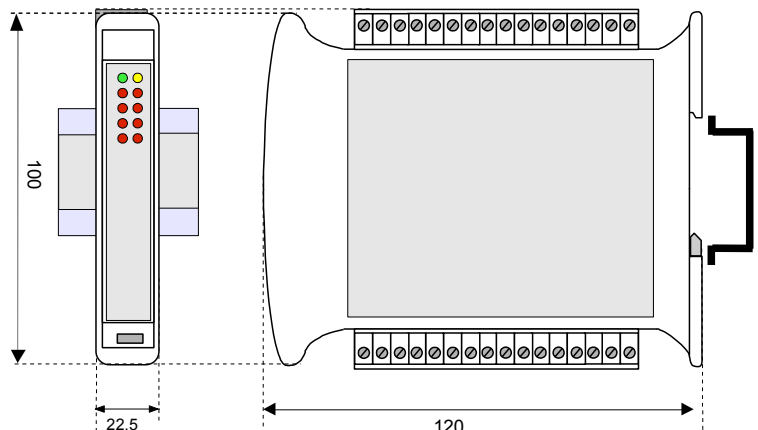

HOW TO ORDER

DAT3011 can be supplied with the configuration specified by the customer. Please refer to the "Technical Specification" section for the output type available.

DAT 3011

■ = Requested
□ = Optional